

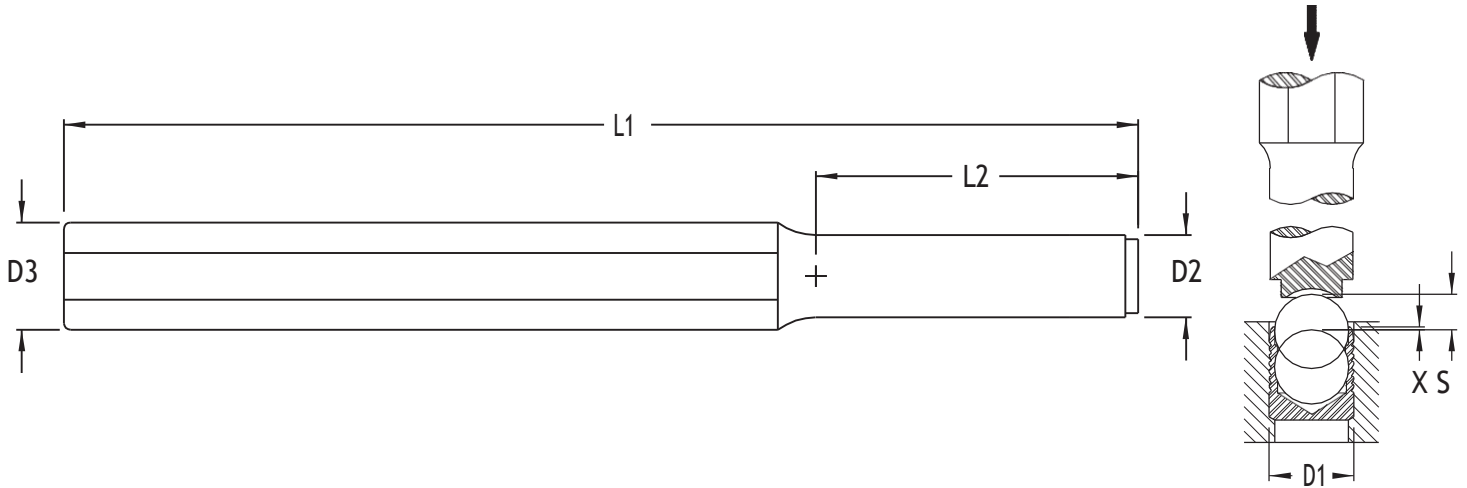

**EIS**  
ENGINEERED  
INSERTS & SYSTEMS, INC.

## Hand Setting Tools - EIS HT Series

Tool Steel  
Heat Treated



EIS-1X, EIS-3X, EIS-5X, EIS-8X (Dimensions in mm unless otherwise specified)							
D1	D1 (in.)	D3 (in.)	L1	D2	L2	X +/- 0.2	Type
2.4	.093S	.375	127	2.2	7.6	0.25	EIS-HT-024
3.0	.125S	.375	127	2.8	10	0.25	EIS-HT-030
4.0	.156 & S	.375	127	3.8	10	0.25	EIS-HT-040
4.5	.187 & S	.375	127	4.8	12.7	0.25	EIS-HT-045
5.0	.218 & S	.375	127	4.8	12.7	0.25	EIS-HT-050
6.0	.250 & S	.375	127	5.8	20	0.25	EIS-HT-060
7.0	.281 & S	.375	127	6.7	20	0.25	EIS-HT-070
8.0	.312 & S	.375	127	7.7	33	0.25	EIS-HT-080
9.0	.343 & S	.500	127	8.5	38	0.25	EIS-HT-090
9.5	.375	.500	127	9.1	38	0.25	EIS-HT-095
10.0	.406 & S	.500	127	9.7	38	0.25	EIS-HT-100
11.0	.437	.500	127	10.7	38	0.25	EIS-HT-110
12.0	.468	.500	127	11.7	38	0.25	EIS-HT-120
14.0	.562	.750	127	13.7	38	0.25	EIS-HT-140
16.0	.625	.750	127	15.7	38	0.25	EIS-HT-160
18.0	.687	.750	127	17.7	38	0.25	EIS-HT-180
19.0	.750	1.00	127	18.7	46	0.25	EIS-HT-190
20.0		1.00	127	19.7	46	0.25	EIS-HT-200
22.0	.875	1.00	127	21.7	46	0.25	EIS-HT-220

**Engineered Inserts & Systems, Inc.**

QMS is Certified IATF 16949: 2016 RoHS Compliant

Phone: 203-301-3334, 203-301-3335

Website: [eisinserts.com](http://eisinserts.com)